

PART I - DESCRIPTION

I-A GENERAL INFORMATION

Comptrol Series 37 Type B and C Tensioncells are force transducers especially designed to measure and control web tension on continuous strip processing lines. They are normally installed in matched pairs at each end of a measuring roll. (See Figure 1 & 2.)

A Tensioncell consists of a unique combination of two integral systems (one mechanical, the other electrical) for converting the mechanical force of strip tension into an electrical signal which is directly proportional to the strip tension.

Type B

Type "B" Tensioncells are designed for use in NON-ROTATING shaft installations. A self-aligning shaft clamp assures proper alignment of the measuring roll when the Tensioncells are bolted to the frame of the machine. Type "B" cells are supplied in matched pairs, one to be mounted at each end of the measuring roll. Note that the cell marked "W2" is a mirror image of "W1". "W2" allows for thermal expansion of the shaft. (See Figure 1.)

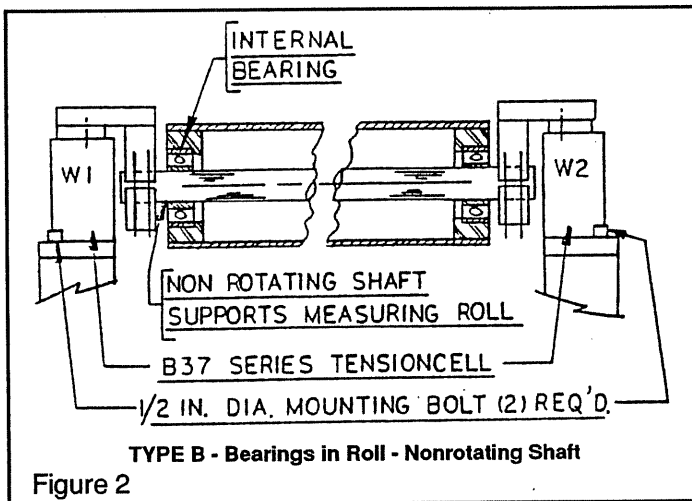

Type C

Type "C" Tensioncells are intended for ROTATING shaft installations. They are supplied with self-aligning ball bearings to assure positive alignment of the measuring roll. Type "C" Tensioncells are supplied in matched pairs, one to be mounted at each end of the tension measuring roll. Note that the cell marked "W2" is a mirror image of "W1". The "W2" cell allows for thermal expansion of the rotating shaft. (See Figure 2.)

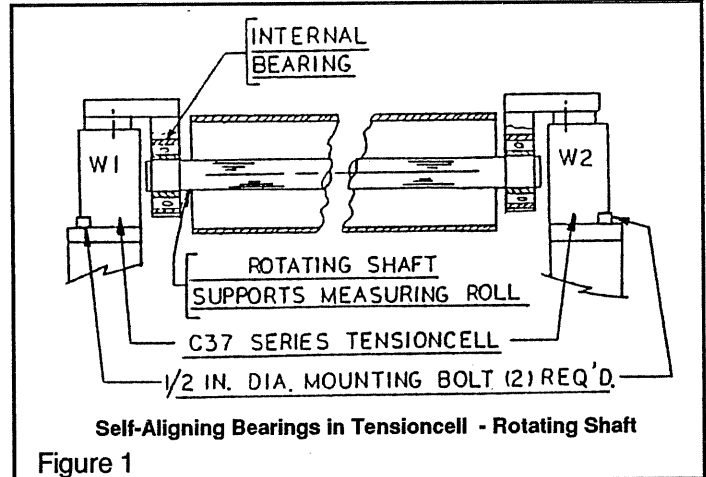

I-B THE MECHANICAL SYSTEM

The mechanical system consists of a Patented "C-Flexure Pivot Assembly" which incorporates a mounting Base Block, frictionless elastic pivot (or hinge), and Load Plate. (See Figure 3.) When a mechanical force is applied to the Load Plate, the pivot permits its deflection toward or away from the Base Block.

(Continued on next page)

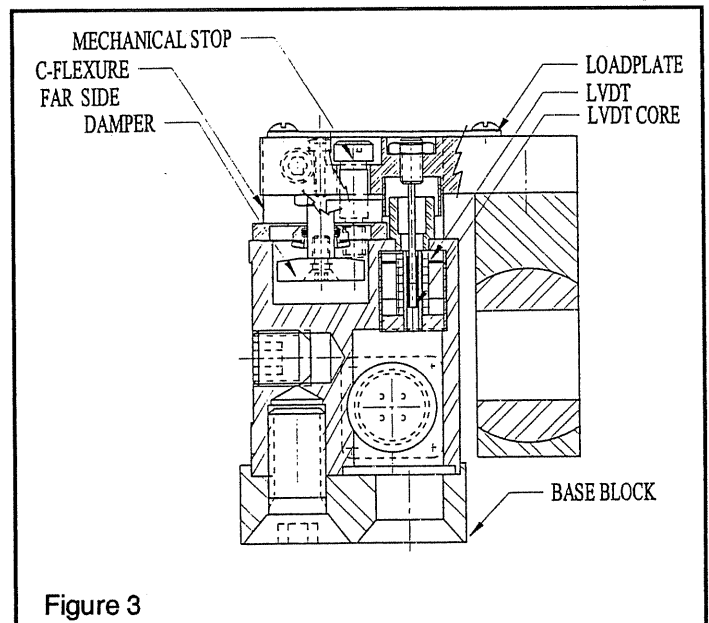

Figure 3

Table of Contents

General Information	1
Installation and Operation	2
Adjustments	3
Troubleshooting	5
Dimension Drawing	6
How To Order	7



For our discussion here, deflection of the Load Plate toward the Base Block is defined as the "Compression Mode", while the opposite is defined as the "Tension Mode". Tensioncells are designed to operate equally well in either mode.

The Base Block contains an integral Mechanical Stop to limit the amount of deflection in either direction, and a Viscous Damper to allow control of the tensioncell response to rapid changes in apparent tension loads. (See Page 1, Figure 3)

I-C THE ELECTRICAL SYSTEM

The electrical system consists of a Linear Variable Differential Transformer (LVDT) which converts the mechanical deflection of the Load Plate into a useful electrical output signal. (See Figure 4.) The movable core of the LVDT is mechanically coupled to the Load Plate by means of the Core Adjust Assembly. (See Figure 4.) This adjustment is factory set and is not accessible.

I-D TYPE "K" DcLVDT

As illustrated in Figure 4, a DcLVDT consists of the following components:

- An oscillator network, which converts the Dc input voltage into a high frequency alternating current for exciting the primary coil (P_1).
- A Primary Coil (P_1).
- A movable, permeable metallic core.
- Two Secondary Coils (S_1 and S_2).
- A demodulator and summing network to rectify and integrate the currents from the Secondary Coils.

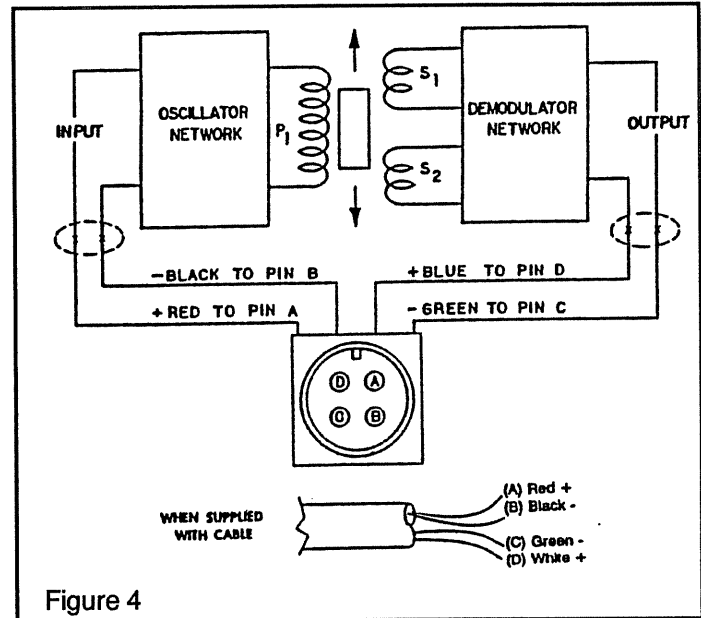

Figure 4

With Comptrol LVDTs, the input and output circuits are electrically isolated from each other and from the mechanical structure of the tensioncell. Thus, they may be used in "floating ground" or "ground return" systems. This eliminates the need for extra circuit boards which are required for most strainage loadcells.

Tensioncells are factory adjusted to provide an offset voltage with no load applied (no deflection). Using an input of 24 volts Dc, the LVDT is set to provide an output of 3.5 volts into a resistive load of not less than 100,000 ohms. The voltage resulting from the maximum rated deflection then adds to or subtracts from the 3.5 volt offset. This results in an output voltage of 3.5 to 6.5 volts in the Compression Mode and 3.5 to 0.5 volts in the Tension Mode. (See Figure 5.)

While acceptable performance may be obtained over an input voltage range of 6.0 to 30.0 volts Dc, the output voltage will vary in direct proportion to the input voltage. Because of this, the use of a well regulated constant voltage power supply is essential for accurate and repeatable tension measurement.

In standard applications, where two Tensioncells are used, the inputs may be connected in parallel allowing the Tensioncells to be excited from the same power supply. The LVDT outputs are then summed to obtain a signal representing the strip tension and tare loads distributed across the roll

Comptrol Tensioncell Controls supply 24 volt Dc and integrate the output signals in a summing amplifier. This permits incorporation of additional circuitry for offset and tare adjustments, as well as adjustments for balance and gain.

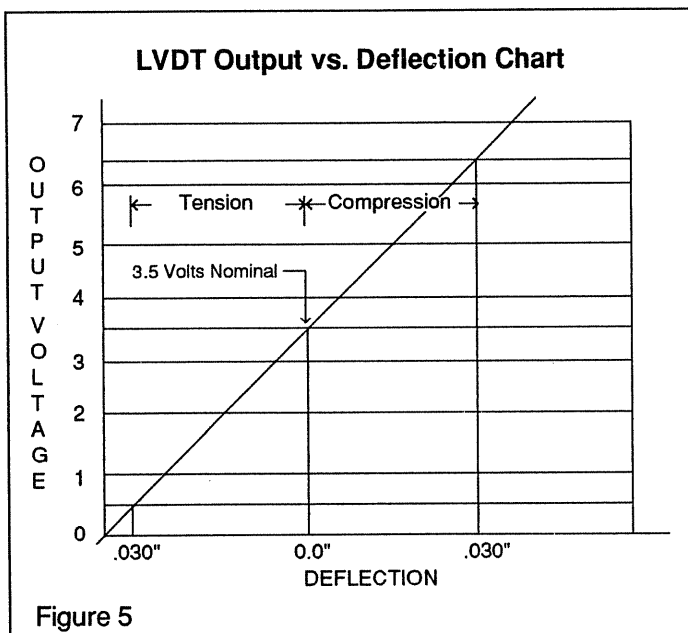

Figure 5



PART II - INSTALLATION AND OPERATION

II-A INSPECTION UPON DELIVERY

Comptrol tensioncells are carefully packaged in sturdy reinforced cartons or wooden boxes and are securely blocked or bolted in place.

1. Upon receipt, examine the exterior of the container for obvious damage or tampering.
2. Check the contents against the packing list.
3. Promptly report any damage or shortage to both the carrier and Comptrol Incorporated.

II-B HANDLING

Tensioncells can be handled manually.

II-C LONG TERM STORAGE

While Comptrol loadcells are plated, exposure to weather, dirt, or moisture should be avoided when they are stored.

II-D MECHANICAL INSTALLATION

NOTE: Refer to the Dimension Drawing on Page 6 of this manual for detailed identification of all parts.

1. Check that the mounting surfaces to which the tensioncells are to be mounted are flat to within 0.002 inch T.I.R.
2. Refer to the loadcell Dimension Drawing on Page 6 for the size, location and orientation of the tensioncell mounting holes to be drilled and tapped in the stands or base structures. (NOTE: When the tensioncells are mounted, the conduit box cover or electrical connector must be accessible.)

Type "K" 24 volt DcLVDT Specifications

Input: 6-30 volts Dc
 Output: 0.5-6.5 volts Dc (nominal, open circuit)
 Output Impedence: 2.5K ohms
 Recommended Load: 100K ohms or greater
 Operating Temp. Range: -65°F to 250°F
 (-53°C to 121°C)

Note: Comptrol loadcells are calibrated for 24 volt Dc input voltage to provide a 0.5 to 6.5 volts Dc output signal. Output voltage will vary proportionally to input voltage.

3. Drill and tap the holes in the stand or base mounting structure to accept the Tensioncell mounting bolts. (See Dimension Drawing on Page 6.)
4. Mount the roll to the tensioncells.
5. Assemble the tensioncells to the stands or base mounting structures.

II-E MECHANICAL ALIGNMENT

Align the sectional measuring roll to avoid any mechanical binding or friction. The measuring roll must be level and perpendicular to the path of the strip material for accurate measurement.

The Mechanical Stops are fixed for the required travel of the Load Table.

II-F ELECTRICAL INSTALLATION

(Read the entire electrical wiring procedure before proceeding.)

1. Turn off all electrical power to the loadcell.
2. Use twisted two conductor signal cable, Belden 9402 or equivalent, in conduit from the LVDTs to the control panel.
3. Observing correct polarity, connect the positive (+) input lead to Pin A and the negative (-) input lead to Pin B. (See Figure 4.)
4. Connect the positive (+) output lead to Pin D and the negative (-) output lead to Pin C. (See Figure 4.)
5. Repeat Steps 1 through 4 of the electrical wiring procedure for the Tensioncells mounted on the other end of the measuring roll.

II-G ELECTRICAL ZERO ADJUSTMENT

(Read the complete Electrical Zero Adjustment procedure before proceeding with the adjustment.)

1. Disengage strip from the measuring roll so that no tension force is applied to the loadcell.
2. Connect a voltmeter to Pins C and D (See Figure 4.)

(Continued on next page)



3. Apply 24 volt Dc electrical power to the loadcell observing the correct polarity. [Plus (+) to Pin D and minus (-) to Pin C.] Do not exceed the maximum rated input voltage.

NOTE: Allow 20 minutes for the loadcell to warmup before taking first readings to insure accurate readings.

4. Measure the output voltage of the LVDT between the Green and Blue leads for each tensioncell with a voltmeter with a sensitivity of at least 100,000 ohms per volt. The output voltage should be between .5 and 6.5 volts.
5. Since Comptrol Tensioncells cannot be mechanically zeroed, refer to the Control Manual for zeroing out the tare weight voltage.

II-H FULL LOAD ADJUSTMENT

After the loadcell has been zeroed, a pull test can be made to check the output voltage of the loadcell at full load. (See calibration sheet for voltage output.)

1. Run a non-stretchable rope over the center of the tension roll simulating the web path. (NOTE: the rolls should be free to turn.)

2. With one end of the rope secured, hang a known weight, equally over the roll so that the total tension is equal to the maximum strip tension specified on the calibration sheet, at the other end. (See Figure 6.)

3. With a voltmeter connected to Pins C and D of the connector, an output voltage will be observed.
4. Repeat Step 3 for the Tensioncell mounted on the opposite end of the measuring roll.

Comptrol loadcells instrumentation provides the required signal conditioning and a reliable high level output signal for use as feedback control of a tension drive system. The feedback signal is directly proportional to the strip tension applied. If a Comptrol control is used, refer to the control manual for further calibration.

Although the electrical output of Comptrol tensioncells are sufficient to drive most electrical indicators, substantial signal conditioning is normally required for effective tension instrumentation system control. Refer to the documentation available from the instrumentation supplier for more information.

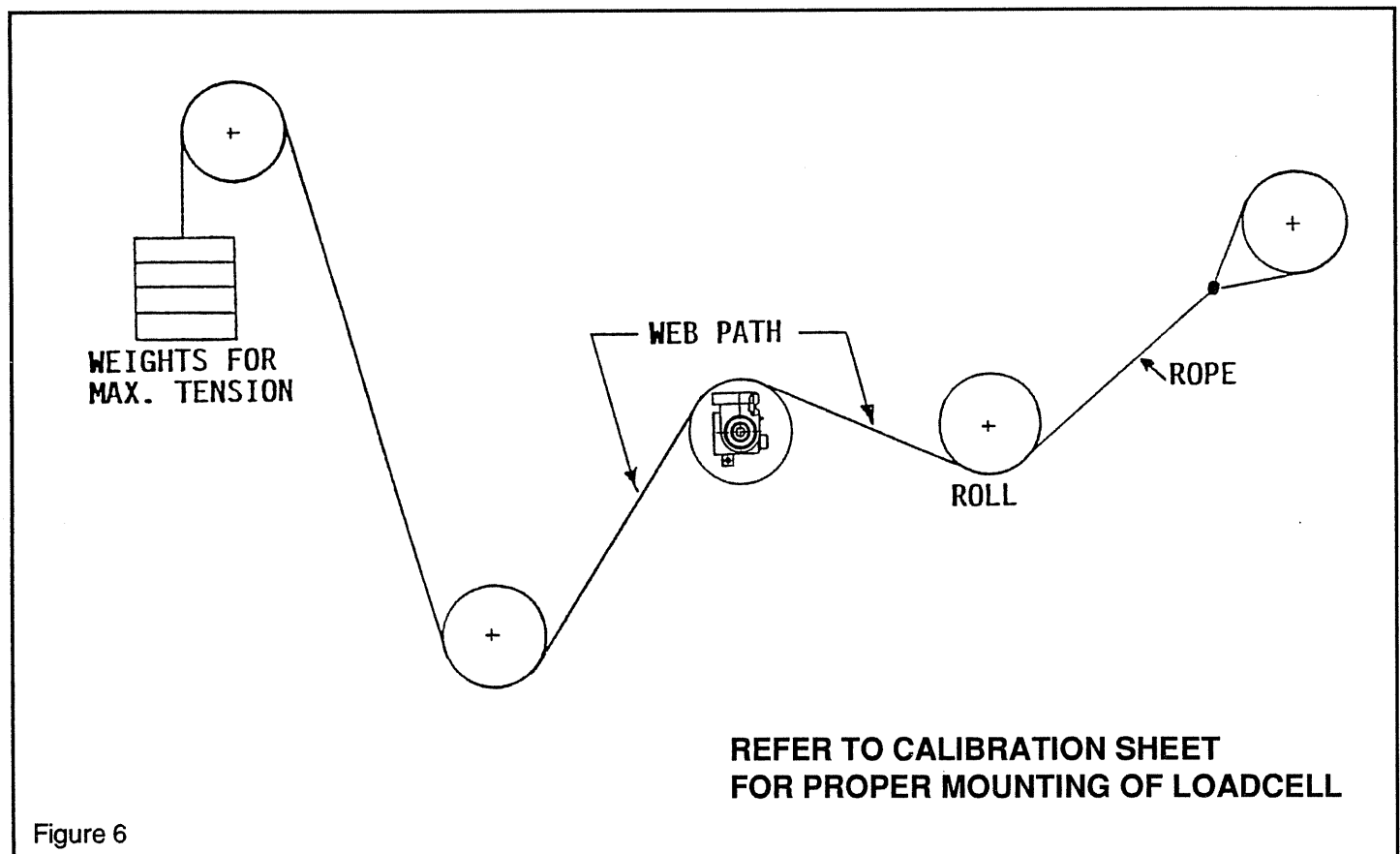

PART III - TROUBLE SHOOTING

When properly installed in accordance with the original design specifications, Comptrol tensioncells should require little or no regular maintenance or service.

Certain conditions, however, can impair their inherently accurate and reliable performance. Therefore, if trouble should arise, the following conditions should be checked.

III-A MECHANICAL

1. Has the tension measuring system been changed?
 - a. An increase or decrease in strip tension (Refer to A on the calibration sheet for specified strip tension.)
 - b. An increase or decrease in the wrap angle.(Refer to B on the calibration sheet for the specified wrap angle.)

If the above parameters have been changed enough to prevent the unit from operating within the limits of the fixed Mechanical Stops, replacement of the Flexure will be required. For this modification, the Tensioncell should be returned to the factory with complete specifications.

2. Are the loadcells mounted securely?
3. Is tension measuring roll in proper alignment and does it turn freely?
4. Are bearings and seals free of all binding and stickiness?
Are they worn?

III-B ELECTRICAL

1. Are LVDTs receiving correct input voltage?
Check line voltage, fuses or circuit breakers, and power switches. Check power supply output and voltage to LVDTs.
2. Are all connections secure?
Check for continuity. Retighten all connections. Recheck operation.
3. Are LVDTs open or shorted.
To check, turn off power and disconnect the input and output leads. Check coil continuity and resistance. (Refer to Figure 4.)
 - a. Pin A to Pin B (Primary Coil) should be in excess of 2 megohms.
 - b. Pin A or Pin B to LVDT shell should be in excess of 5 megohms.
 - c. Pin C to Pin D (Secondary Coil) should be approximately 20,000 ohms.
 - d. Pin C or Pin D to LVDT shell should be in excess of 5 megohms.

If LVDT circuits are open or shorted, replace LVDT. Contact Comptrol with tensioncell model number and serial number.



MODEL NUMBER NOMENCLATURE EXAMPLE

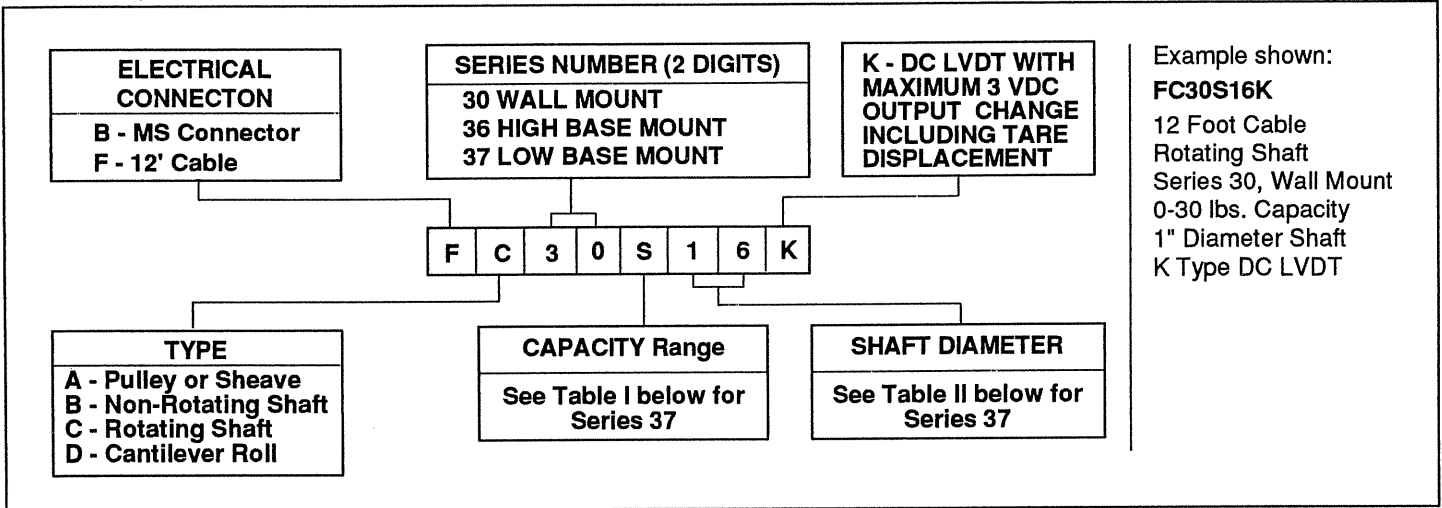
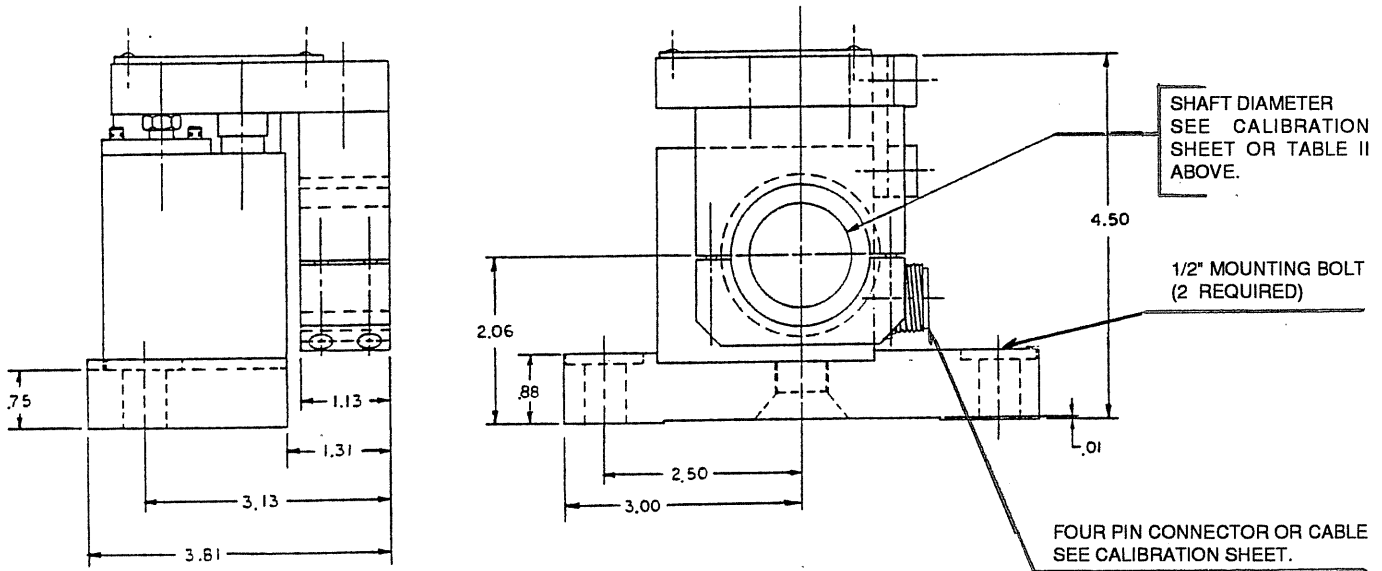

TABLE I SERIES 37 CAPACITY RANGE CODE									
CODE	A	P	S	T	U	W	X	Y	Z
POUNDS	Spec	0-20	0-30	0-50	0-90	0-140	0-200	0-300	0-500

TABLE II SERIES 37 SHAFT SIZE CODE							
CODE	12	14	16	18	20	22	24
INCHES	3/4	7/8	1.0	1-1/8	1-1/4	1-3/8	1-1/2

DIMENSION DRAWING SERIES 37, TYPE B & C



HOW TO ORDER TENSIONCELLS AND CONTROLS

Our Application Engineering Department will make all calculations and offer installation suggestions as part of our formal quotation. To help us provide these services, we request that you furnish us with complete information about your requirements. If possible include a drawing or sketch of your application, noting the preferred position of the electrical conduit box. The information listed below is the MINIMUM we require: (Refer to illustration below.)

- Maximum Strip, Web, or Strand Tension (A)
- Total Wrap Angle (B)
- Inclination of the Passline with respect to horizontal (C)
- Total Weight of the roll and bearings (or sheave and bearing) (TW)
- Shaft Diameter
- Rotating or Non-Rotating Shaft
- Measuring Roll Diameter (in inches)
- Maximum Machine Speed (FPM)

Include the Model Number of the Loadcell Control Required.

When placing your order, please include instructions as to how the equipment and/or shipping containers are to be marked. Loadcells are assembled from stock parts for fast delivery.

When ordering spare, or replacement parts, please reference the Model and Serial Number of the original equipment. Comptrol maintains complete files and documentation on all loadcell equipment.

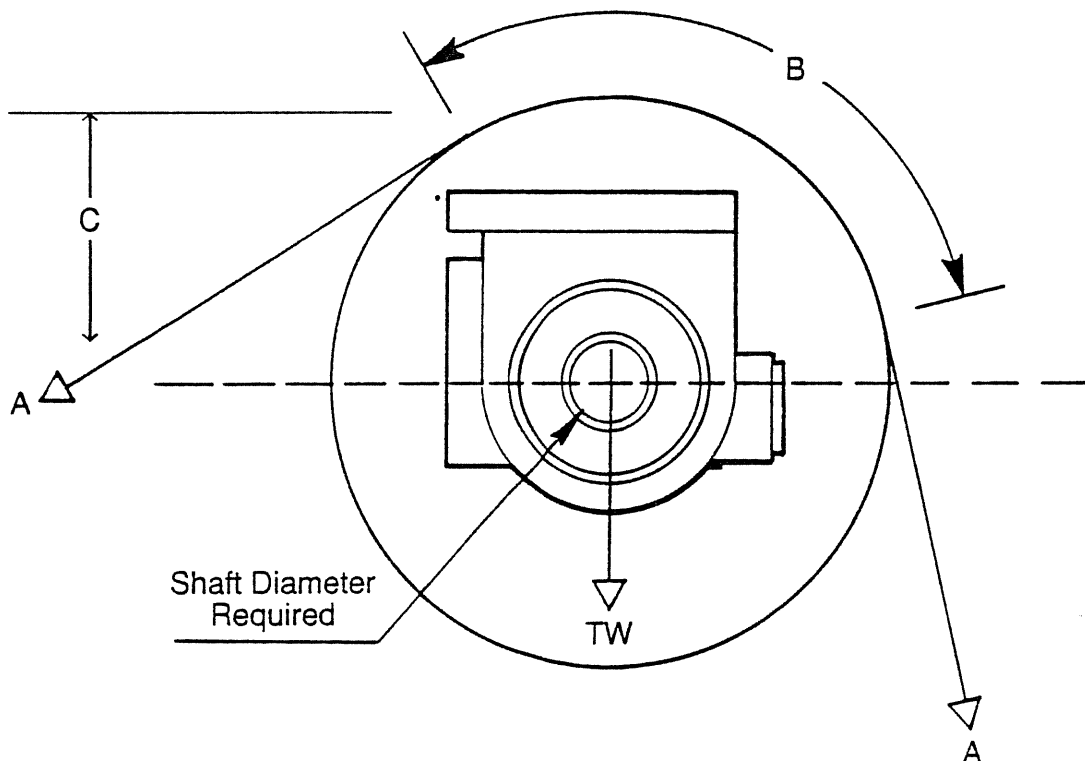

COMPTROL MANUFACTURED PRODUCTS

BALLSCREW PRODUCTS

- Inch and metric rolled thread ballscrews
- Precision ground ballscrews
- Single and preloaded ballnuts for base, flange, cut-off flange, or trunnion mounting
- Base, flange, or cut-off flange mounted end bearing supports
- Custom and modified units also available

COMPLETE BALLSCREW PACKAGES

Comptrol complete ballscrew packages feature standard pre-engineered Comptrol products to provide ready-to-install ballscrew "package" consisting of the ballscrew, ballnut, and end mounting bearing supports. Custom and modified standard assemblies are also available.

HIGH SPEED LINEAR POSITIONERS

Comptrol industrial linear positioners for applications requiring stroke lengths up to 36 inches, load capacities up to 5,000 pounds, and speeds up to 50 inches per second.

QUALITY VERIFICATION SYSTEMS

Comptrol Rod and Piston Systems

An industry standard for over 20 years in reciprocating engine plants around the world, Comptrol Connecting Rod and Piston Balancing Systems provide an accurate, high speed method of weighing and balancing connecting rods and pistons on automatic engine transfer lines.

Comptrol Weighcells Systems

Ideal for automatic assembly and packaging systems, Comptrol weighcells provide a high speed, continuous method of monitoring of process quality. These systems can detect weight deviations within 0.1 gram of the ideal weight in 0.8 seconds.

TENSION MONITORING SYSTEMS

Comptrol tension monitoring systems are designed to measure and control strip or web tension of continuous process lines. Available in over 30 models with capacity ranges from 4 to 20,000 pounds, these units are ideal for new, replacement and retrofit applications.

COMPTROL TECHNICAL SUPPORT

ENGINEERING

- Application Assistance
- Mechanical Design
- Electrical Design
- Software Design

CUSTOMER SUPPORT

- Field Service Support
- Project Planning
- Installation Supervision and Assistance
- Installation Inspection
- Documentation

MANUFACTURING

- Electrical and Mechanical Assembly
- In-house Machining

The information contained in this document is subject to change without notice. Comptrol Incorporated has made every effort to insure the accuracy and completeness of the descriptions and procedures discussed in this document. Failure to comply with these procedures may result in personal injury, or damage to the Comptrol product or the equipment used in conjunction with it.

Comptrol Incorporated assumes no liability for incidental or consequential personal or equipment damages arising from the use of this document, the software and hardware described, or failure to comply with the procedures contained in this document.

Note that protective covers or guarding may not be shown in some illustration to provide a clearer view of specific components or assemblies. All protective covers and guarding must be installed before operating the unit.

Reproduction, copying, or the disclosure to any third party for any unauthorized purpose, of the contents or software contained or described in this document is prohibited without written authorization from Comptrol Incorporated. Violators will be prosecuted.

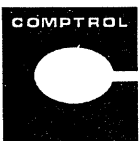

COMPTROL INCORPORATED

9505 Midwest Avenue Cleveland, Ohio 44125
Phone: (216) 587-5200 • FAX: (216) 587-5210

