

B36 NON-ROTATING SHAFT MOUNTING
C36 ROTATING SHAFT MOUNTING

CAPACITY RANGE - POUND											
NOMINAL	0-4	0-8	0-13	0-20	0-30	0-50	0-90	0-140	0-200	0-300	0-500
CODE	L*	M*	N	P	S	T	U	W	X	Y	Z

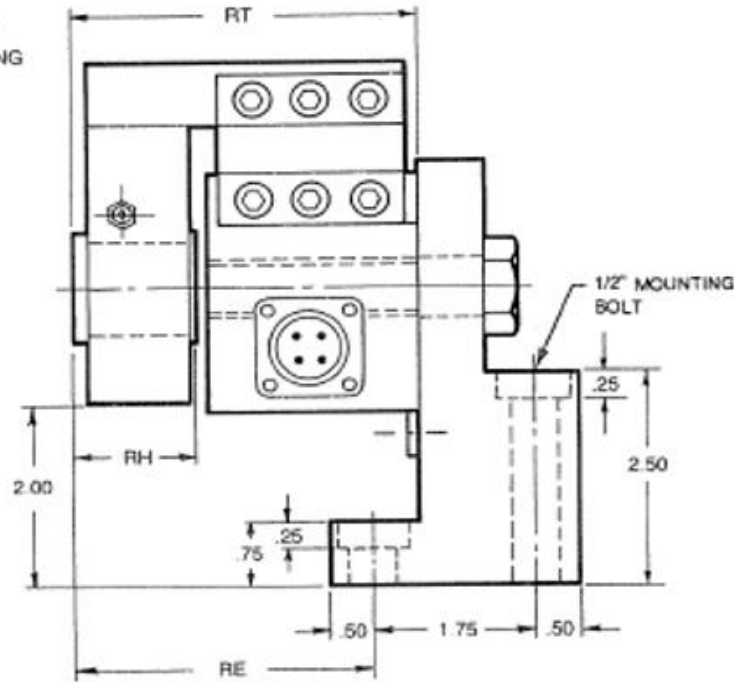
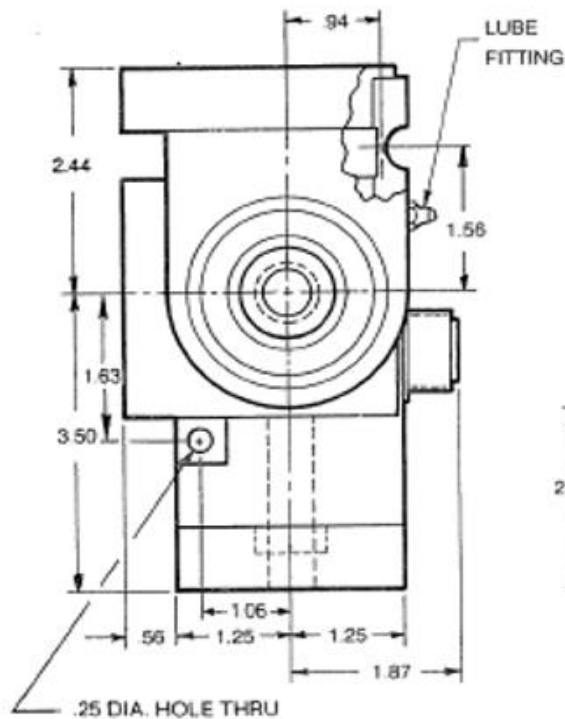

W1 unit shown here.
W2 unit is applied at the opposite end of roll.

W1 unit clamps the shaft while
W2 unit allows for temperature expansion of the shaft.
Both units have self-aligning features

Fifteen standard shaft diameters.
For rotating shaft see Table III C.

TYPE B SHAFT DIAMETERS - INCHES									
Inches	1/2	5/8	3/4	7/8	1	1-1/8	1-1/4	1-3/8	1-1/2
Code	08	10	12	14	16	18	20	22	24
RH	1.00			1.13					
RT	3.63								
RE	3.13								

TYPE C SHAFT DIAMETERS - INCHES								
Inches	1/2	9/16	5/8	11/16	3/4	7/8	15/16	1
Code	08	09	10	11	12	14	15	16
RE	3.31							
RH	1.31				1.38			
RT	3.81							
Inches	1-1/16	1-1/8	1-3/16	1-1/4	1-5/16	1-3/8	1-7/16	
Code	17	18	19	20	21	22	23	
RE	3.53			3.63				
RH	1.53			1.69				
RT	4.03			4.13				

*Tensioncells in this range supplied for shaft sizes up to maximum 3/4" diameter unless approved by factory.

The information contained in this document is subject to change without notice. Comptrol has made effort to ensure the accuracy and completeness of the descriptions and procedures discussed in this document. Failure to comply with these procedures may result in personal injury, or damage to the Comptrol product or the equipment used in conjunction with it.

Comptrol assumes no liability for incidental or consequential personal or equipment damages arising from the use of this document, the software and hardware described, or failure to comply with the procedures contained in this document.

Note that protective covers or guarding may not be shown in some illustrations to provide a clearer view of specific components or assemblies. All protective covers and guarding must be installed before operating the unit.

Reproduction, copying, or the disclosure to any third party for any unauthorized purpose of the contents or software contained or described in this document is prohibited with written authorization from Comptrol. Violators will be prosecuted.